

# KIRA

## Bench type Drilling Machine KID-420 INSTRUCTION MANUAL

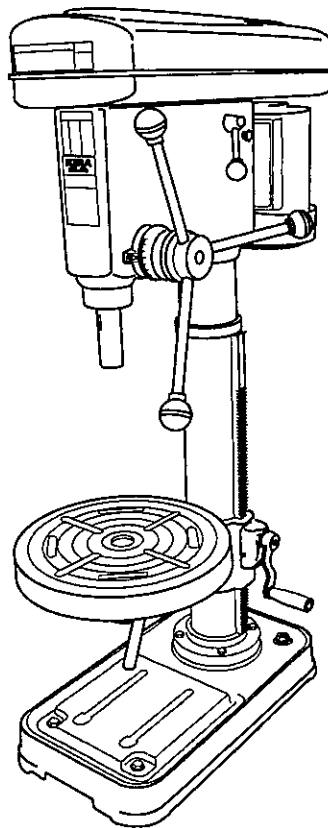

### **▲ CAUTION**



◆ *This instruction manual includes important information for using the KID-420 properly and safely.  
Be sure to read and understand this document before using the Bench type drilling machine.*

# KIRA CORPORATION

DOC1-42-EOM10-1



## PREFACE

Thank you for purchasing the Model KID-420 KIRA Bench type Drilling Machine. This instruction manual uses a number of illustrations to help your understanding. Be sure to read and understand the instruction manual before starting the KID-420 operations. Place the manual in a location where it can be accessed whenever necessary.

## SIGNAL WORDS

The signal words as used in this instruction manual and on the KID-420 represent the following three levels of hazards:







<b>⚠ DANGER</b>
◆ <i>Indicates an imminently hazardous situation which, if not a voided, will result in death or serious injury.</i>
<b>⚠ WARNING</b>
◆ <i>Indicates a potentially hazardous situation which, if not avoided, could result in death or serious Injury.</i>
<b>⚠ CAUTION</b>
◆ <i>Indicates a potentially hazardous situation which, if not avoided, many result in minor or moderate injury, or property damage to the equipment.</i>







### NOTE

*Indicates something that must be considered in handling the equipment.*

## ICONS

This instruction manual uses the following icons to raise your attention:

Caution ( including Danger and Warning )		Electric shock
		Injured by spindle or tool
		Flied out
		Caught in rotating part
		Fire
		Get caught in belt

Caution		Other general cautions
		Do not contact or access
Prohibition		Do not disassemble
		Do not wear gloves
Compulsion		Refer to instruction manual
		Ground

## DESCRIPTION OF SIGNAL-WORD LABELS

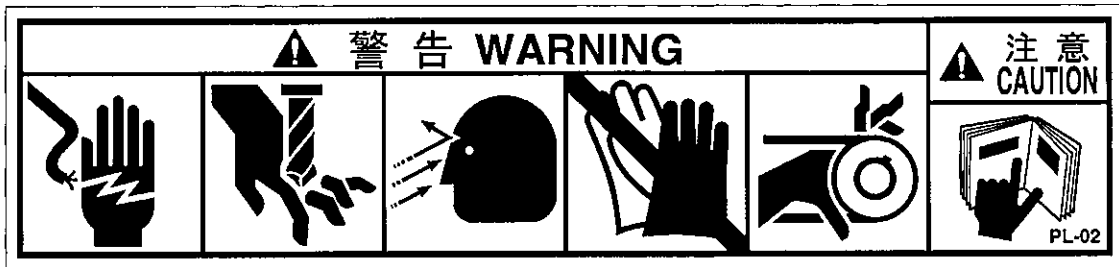

*[Risk of electrical shock]*

*High voltage runs in the electric control cabinet. Getting an electric shock may result in death.*

*Therefore, before opening the door on the electric control cabinet, be sure to shut off the main power.*



*[Warning of electrical shock label]*

*There might be had an electric shock because high voltage runs in the electric control cabinet if the control panel is opened carelessly or is attached with a wet hand.*

*Don't open or remove the portion which is attached this label.*



*[Risk of injured by spindle]*

*The spindle has a sharp cutter that rotates at a high speed. Touching the spindle during its rotation results in serious injury like severing. Therefore, do not put your hand or foot close to the rotating spindle.*

*Even if the spindle stops, do not touch it with a bare hand.*

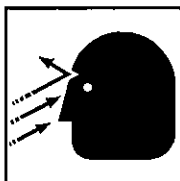

*[Risk of eye injury]*

*"Chips / cutting oil / broken tools" are scattered during processing. There is a chance to injuring eyes or face. The protection glasses must be worn while operating machine.*



*[Must not wear gloves while operating machine]*

*There is a chance to be injured by the rotating objects of machine pulls or rolls up the glove.*



*[Must not operating machine without covers]*

*There is a chance the rotating belt catches fingers or hands, if operate machine with opening cover etc. If the fingers or the hands are stuck in the belt, stop the machine immediately and turn off the main power. Then rotate the belt by hand in order to release the stuck fingers or hands. Turn off main power when open cover etc.*

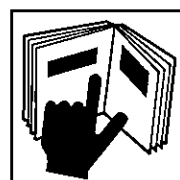

*[Be sure to read and understand the contents of this manual before operating]*

*Improper operations may cause unexpected accidents or machine malfunctions. If the Instruction Manual is lost, please contact your dealer for purchasing new one.*

# LOCATIONS FOR STICKING SIGNAL-WORD LABELS

## ⚠ DANGER

◆ Do not use the equipment when any of its signal-word labels is partially or totally broken, peeled off, or has a faded color. This may result in serious damage.

- \* Two different kinds of warning label is stuck on the equipment.
- \* If the warning label is broken, peeled, or discolored, contact your dealer with its label number.

LABEL No.: PL-02

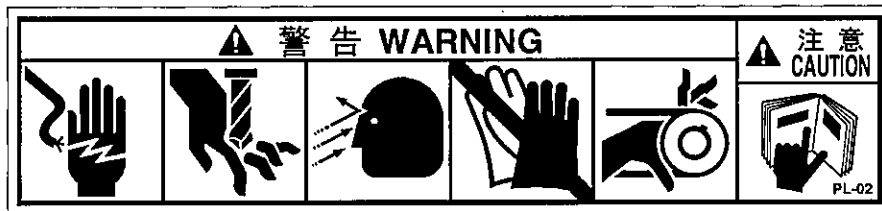

【Model】 KID-420

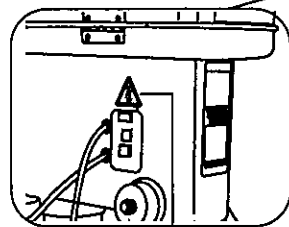

POWER-SEAL-M

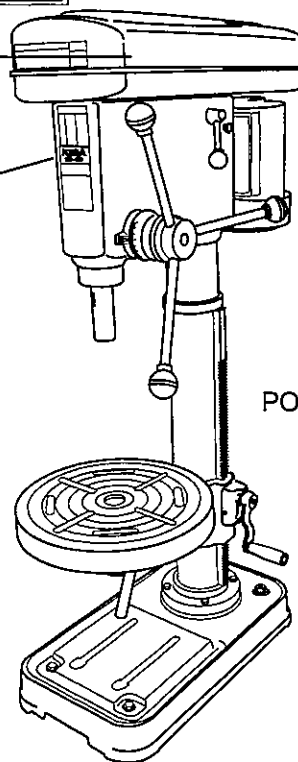

POWER-SEAL-M

## SAFETY PRECAUTIONS

### ⚠ DANGER



- ◆ The main power must be shut down, before opening the door on the electric control cabinet.
- ◆ Do not operate switches by a wet hands.

### ⚠ WARNING



- ◆ Do not touch the spindle or chips during the operation. Especially the cutter is very sharp. Do not touch it, even if the spindle is not rotating.



- ◆ Do not approach all fours to belt while rotating, may be caught in the belt.
- ◆ Do not operate machine with opening cover etc.
- ◆ Be careful not to punch hand between pulley and belt while belt changing operation.
- ◆ Turn off main power when open cover etc.



- ◆ Do not wear the gloves during operation. Your gloves and hands may get stuck in the rotating part of the machine.



- ◆ The KID-420 may suddenly start moving after it temporarily stops during the operation. Therefore, do not access the equipment without verifying its present state.



- ◆ If cutting oil attaches to your working wear, clean it off because it may catch fire.
- ◆ Exercise care in handling cutting oil. For example, in order to prevent fire occurring with cutting oil, do not use water-insoluble cutting oil when carrying out operation. If the floor is made of wood, use sufficient care for fire because it is liable to catch fire. And please confirm the location of fire extinguisher before operation start.



- ◆ To remove chip stuck on a tool, stop the spindle; checking that its rotation has completely stopped; and then brush off the chip while wearing protective glasses, and please do not touch cutting chips barehanded.

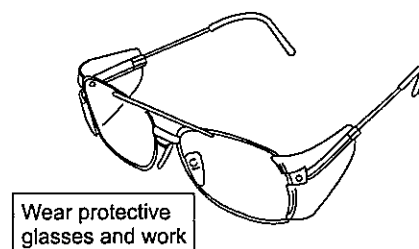
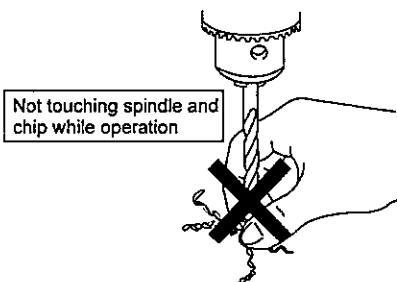

**▲ WARNING**

- ◆ Be sure to fix the workpiece to the table using a vise, etc.  
If machining is carried out without fixing the workpiece, it would be rotated or lifted up to cause very dangerous situation.

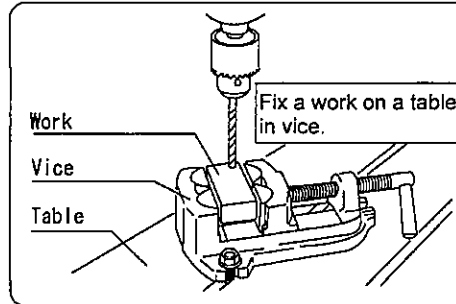

- ◆ Please be careful to the handling of a work. Letting it fall on your foot will result in a bone fracture or a similar injury.



- ◆ Be sure to ground the equipment.  
But, do not connect the grounding to the gas pipe and steel frame which have insufficient grounding.



- ◆ Be sure to connect the wire of power to the power supply in which a leakage breaker is set.
- ◆ Do not install the drilling machine outdoors, in the location where is much moisture, where is splashed by water, or where is exposed to direct sunlight.
- ◆ Do not use the machine in the location where is flammable liquid or gas.



- ◆ Confirm the position of button to stop spindle rotation immediately.
- ◆ Stop the machine and shut off the power before "Maintenance & inspection" or "Changing tool, cutter or fixture".  
If any hazardous situation may be predicted, also shut off the power.
- ◆ Set up the caution plate in a conspicuous place around the service panel and the control box while working in order to prevent somebody turns on the power suddenly.



- ◆ Install the tooling and the cutter firmly to the normal position by appropriate procedures. Loosely or too much tighten is dangerous. Follow the procedures mentioned in manual.



- ◆ Before turning ON the power, check that the maintenance tools such as chuck handle, wrench, center drift etc. have been removed.

**▲ CAUTION**

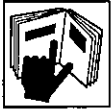

- ◆ Be sure to follow the instructions given in this document, including the operation guidelines.
- ◆ Do not use the KRT-10 for any purpose other than specified in manuals.
- ◆ Do not use the machine for any purpose of cutting wooden material and similar material
- ◆ This model is vertical type, and install to strong working table etc to prevent overturning.



- ◆ Do not carry out disassembling or modifying by yourself.
- ◆ Use the KID-420 at the specified frequency and voltage.



- ◆ Check no damage on covers and other parts before operation.
- ◆ Clean up the machine and wipe up the cutting oil around the machine after operations. Then add the lubrication oil to the designated points.
- ◆ Perform maintenance / inspection regularly.



- ◆ Making operations with wearing appropriate clothes, safety shoes, safety glasses and other protective equipment.



- ◆ Do not operate the machine other than the person in charge of operation.
- ◆ Do not make uncertain operation or procedure.
- ◆ Do not place something not related to operations on the machine or around it.
- ◆ Shut off the power in case of power failure.
- ◆ Shut off the power while the machine is out of use.
- ◆ If the spindle crashes on the workpiece, stop the operation immediately. Then contact your dealer or KIRA Corporation for asking recovery procedures.
- ◆ If you found any abnormal condition on the machine, stop the operation immediately. Then contact your dealer or KIRA Corporation.



---

# - CONTENTS -

PREFACE .....	1
SIGNAL WORDS .....	1
ICONS .....	1
DESCRIPTION OF SIGNAL-WORD LABELS .....	2
LOCATIONS FOR STICKING	
SIGNAL-WORD LABELS .....	3
SAFETY PRECAUTIONS .....	4
CONTENTS .....	7
1. NAMES OF VARIOUS PARTS .....	8
2. SPECIFICATIONS .....	9
3. USE APPLICATION .....	9
4. PREPARATIONS FOR OPERATION .....	10
5. CHECKS BEFORE OPERATION .....	11
6. DRILLING OPERATION .....	12
7. MAINTENANCE AND CHECK .....	14
8. DIMENSION .....	15
9. PARTS LIST .....	19
10. DISPOSAL AND RESELLING .....	23
11. WARRANTY .....	24

# 1 . NAMES OF VARIOUS PARTS

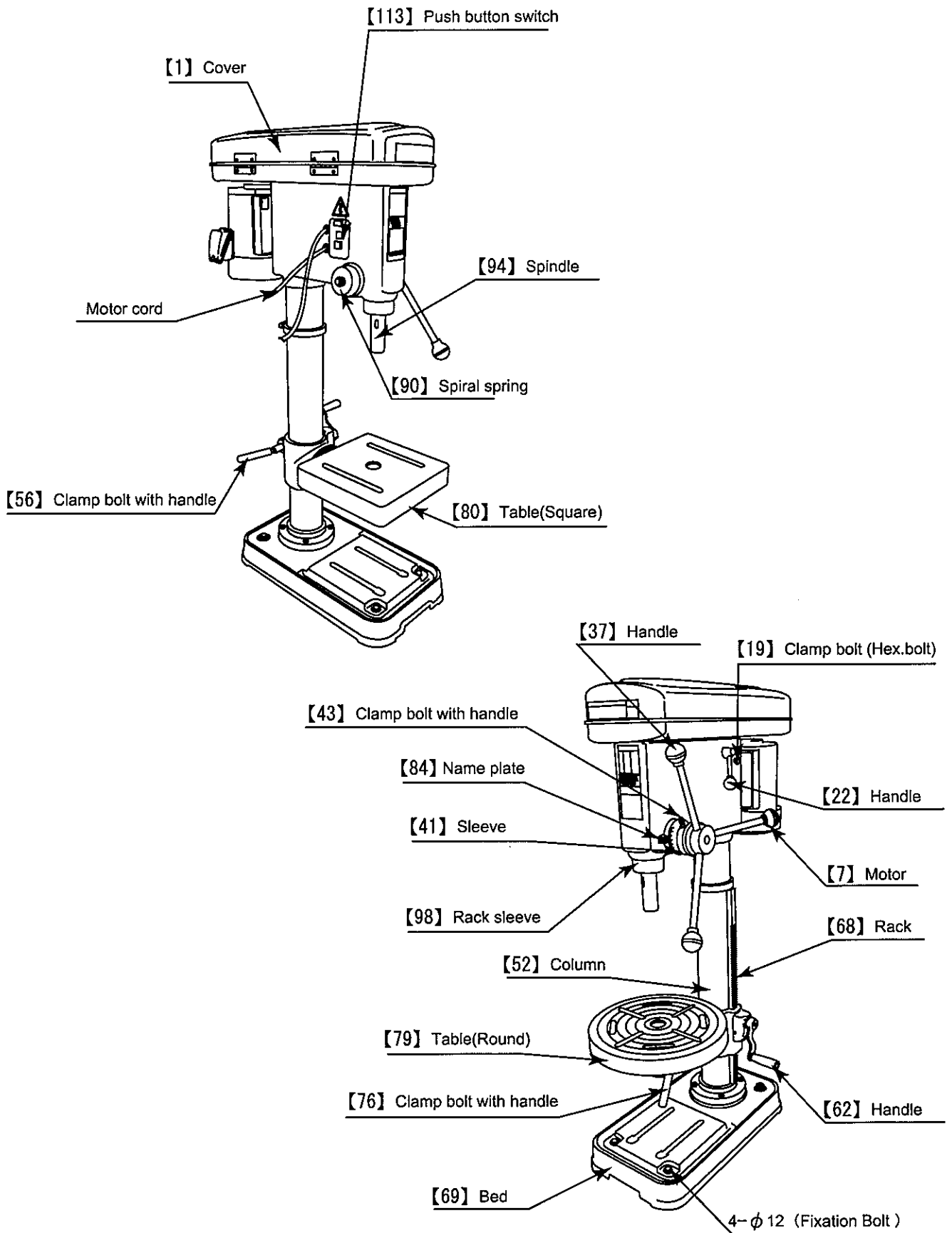

※A number of a name of each part please refer to parts list

## 2 . SPECIFICATIONS

Unit : mm

Model		KID-420	
Swing		420	
Drilling capacity	S45C	4~19	
	FC200	4~23	
Max. distance spindle to Table		Round table	425 [485]
		Square table	470 [530]
Max. distance spindle to base		663 [720]	
Up-and-down motion of spindle		120	
Spindle taper		MT2 [ MT3 Option ]	
Size of a table	Round table	φ370	
	Square table	□300	
Up-and-down motion of table		425	
Spindle Speed (min <sup>-1</sup> )	50Hz	4P	250,370,620,1400,1650,2500
		6P	170,250,420,950,1150,1750
	60Hz	4P	300,450,750,1700,2000,3000
		6P	200,300,500,1150,1400,2100
Power supply		Three phase 200V 50/60Hz	
Drive motor		0.75kW 4P (Totally enclosed type)	
		0.75kW 6P (Totally enclosed type)	
Type of V-Belt	4P	A-34-R,A-26-R	
	6P	A-34-R,A-27-R	
Machine total height		1279	
Net weight(kg)		130	
Dimension of base		340×600	
Accessories		Center drift 1 piece	

※Value in [ ] is for machine of MT3 specification

## 3 . USE APPLICATION

Drilling of various materials, S45C(steel),FC200(Cast iron) ,etc.

## 4 . PREPARATIONS FOR OPERATION

### (1)Installation

Install the machine on the smooth top working table which is reserved enough space for making inspection and maintenance.

Since bed [69] has four holes, please fix with bolt.

### (2) Power supply

The power supply should prepare the power supply in which power supply breakers, such as an earth leakage breaker, are installed.

Since it is displayed on the motor face plate, please prepare electric power capacity and the voltage after check.

### (3) Wiping off rust prevention paint.

Wiping off the rust prevention paint of bed [69], table [79,80], spindle taper [94] and column [52]. Please wipe off cleanly.

### (4) Refilling of lubrication oil

Refill the lubricating oil to following points.

Lubrication point	Method	Quantity of oil	Brand name	Cycle
[98] Rack sleeve	Manually	4~6drops	Shell Tonna Oil S3M68	once / 1day
[90] Spring	Manually	4~6drops	Shell Tonna Oil S3M68	once / 1day
[52] Column outside	Manually	4~6drops	Shell Tonna Oil S3M68	once / 1day
[68] Rack	Manually	4~6drops	Shell Tonna Oil S3M68	once / 1day
Other sliding and rotating part	Manually	2~3drops	Shell Tonna Oil S3M68	sometimes

※Application oil is listed Sell brand. If you use other brand oil, please use equivalent oil as the above table.

※Lubrication of a rack sleeve, Please lubricate after all taking out a rack sleeve.

### (5) Attachment of drill chuck

a. Please wipe well oil of the taper part at the tip of spindle [82], and the taper part of drill chuck with clean cloth etc.

b. Please insert drill chuck into spindle taper, and strike and attach with wooden hammers, after making three pawls of the drill chuck draw.

### CAUTION

◆ *Oil has attached to taper, or if insertion is insufficient, chuck drops out and it is dangerous.*

*(It will become impossible using Spindle, if chuck drops out and a crack is attached to the taper.)*

### (6)The check of a V belt

a. Please open cover [1] and check whether the V belt [4] is installed properly.

In addition, refer to "6-3 The conversion of spindle rotation speed" for how to install V belt and change spindle speed.

b. After check should close the cover [1] at any cost.

## 5. CHECK BEFORE OPERATION

### (1) The check of power supply

Once again, please check in what has power supply of preparation the same as the power supply << three phase 200V>> of the display on motor [7] face plate.

### (2) About starting push button switch.

The push button switch [113] which is attached on left-hand side performs "ON" and "OFF" of the motor.

### (3) Connection of power supply (Three phase 200V)

The power source wire is attached in a 4 cores cab tire cord with 2m length.

Please connect 3 wires with the power supply breaker certainly.

The earth wire is attached in the code (green) 2m length, please connect with the grounded earth wire. Please do not connect with a gas pipe and a steel frame insufficient in installation.

### ⚠ CAUTION

- ◆ *When you connect a power cord, please be sure to turn "OFF" a power supply breaker and the push button switch, and to perform them.*
- ◆ *Please connect an earthed line (green) to ground by all mean. Please connect power cable to the place where the earth leakage breaker is prepared.*
- ◆ *Please connect power cable to the earth leakage breaker.*

Power Three phase 200V 50/60Hz

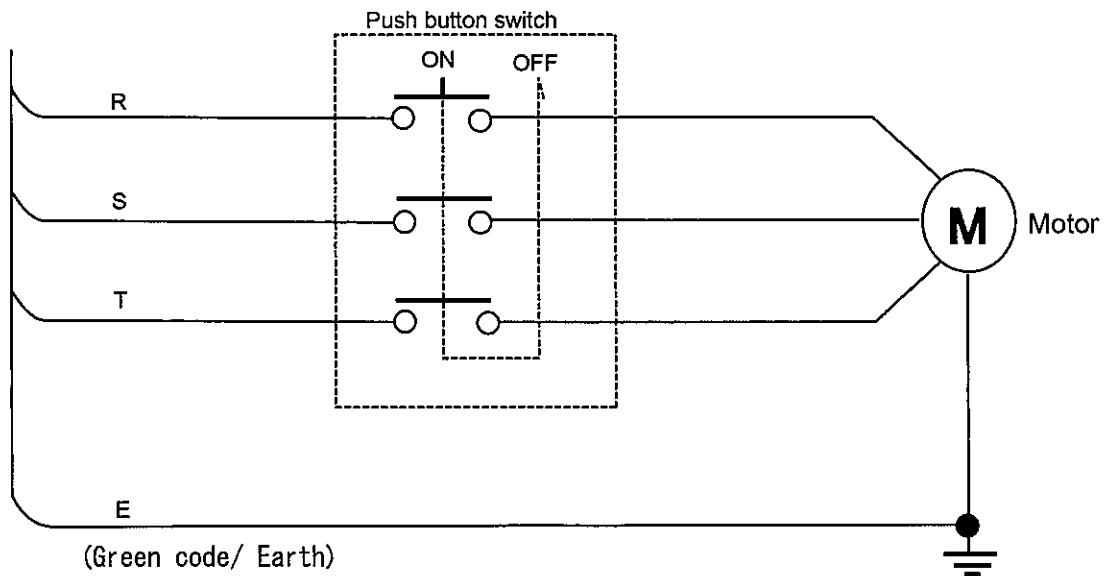

### (4) The check of rotative direction of spindle.

Please turn "ON" push button switch. It is normal, if the spindle rotates clockwise direction with the view from top of the machine.

Please replace two of three of a power source wires (R.S.T.) after pushing "OFF" and turning off power supply breaker, if the spindle rotates counterclockwise direction.

## 6 . DRILLING OPERATION

### (1) Attachment of drill

Please attach a drill certainly to drill chuck without run-off.

### (2) Feeding depth adjustment of spindle (drilling depth adjustment)

If clamp bolt with handle [43] of Sleeve (scale ring) [41] is loosened, Sleeve (scale ring) [41] can be turned freely.

As this sleeve has stopper and fix given position, the spindle stroke (drilling depth) can be determined. One division of the sleeve is 1 mm of spindle stroke.

For example, if you want to move spindle down 50mm, please loosen the fixed bolt, turn sleeve until the line of 50 of the scale [41] with name plate [84] and tighten clamp bolt [43]. If handle [37] is turned and a spindle is moved, then will stop at the place "0" of the scale of sleeve corresponded with the name plate[84].

The spindle is moved 50 mm.

### (3) Conversion of spindle rotation speed

Spindle rotation speed is convertible for six steps by changing belt position as name plate of the front of the head and Fig-2.

Belt position	Spindle speed(rpm)			
	60Hz		50Hz	
	4P	6P	4P	6P
1 · 6	3000	2100	2500	1750
1 · 5	2000	1400	1650	1150
2 · 6	1700	1150	1400	950
3 · 5	750	500	620	420
2 · 4	450	300	370	250
3 · 4	300	200	250	170

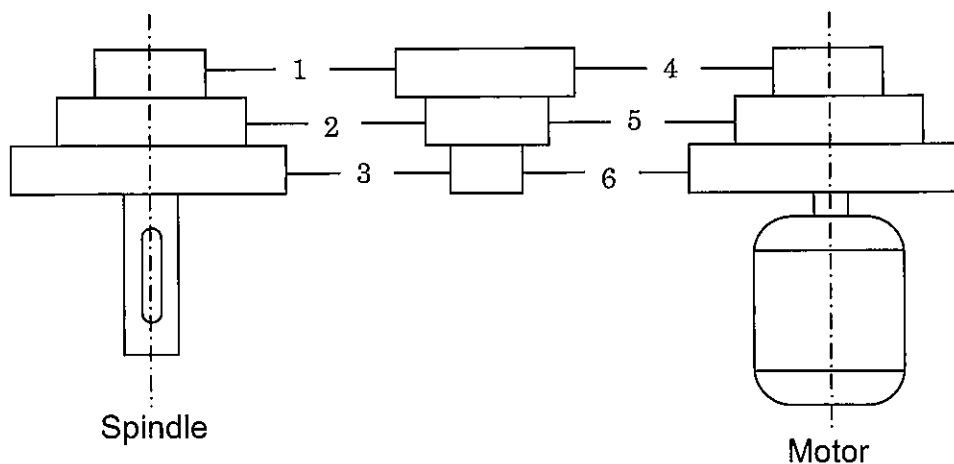

Fig-2

## ② Changing belt position

**⚠ CAUTION**

◆ *Be careful not to pinch hand between pulley and belt.*

- a. The motor can move forward and backward by handle [22] after loosening clamp bolt [19]. It is possible to loosen and tighten the belt by the handle.
- b. There are three pulleys of motor pulley [3], spindle pulley [111] and middle pulley [33], and 2 steps shift is available by 2 belts as Fig.2. Please use the belt of [4P=A-26] [6P=A-27] between motor pulley and middle pulley, and [4P, 6P=A-34] between spindle and middle pulley.
- c. When you want to tighten the belt, please move handle [22] to the direction which can tighten the belt. As middle pulley [33] is fixed through coil spring [29], both belts are tighten together.
- d. When you want to loosen the belt of motor pulley, please move handle [22] to the opposite direction of above "c". When you loosen the belt of spindle pulley, please push both sides of the belt to inside by hands, and middle pulley is moved, then the belt is loosened.

## (4) Cutting oil

Suitable cutting oil to machining condition should be used. Please do drilling using suitable cutting oil.

## (5) Workpiece fixing

Please be sure that workpiece is fixed properly to vice etc. and fix the vice to table.

If workpiece is drilled without right fixing, workpiece rotates and it is very dangerous.

## (6) Adjustment of table height

It is necessary to adjust the table [79, 80] height to work easily. When clamp bolt with handle [56] is loosened and handle [62] is turned, table can move up and down.

After height adjustment, please bind clamp bolt [56] tight firmly.

If drilling operation is done in case of loosened the clamp bolt, table may be slant or moved, drill hole may have angle. Please be sure to tighten clamp bolt [56] firmly.

## (7) Drilling

**⚠ WARNING**

◆ *Do not touch rotation portion by any means (drill, chips, etc.).  
Hand is pinched and it is very dangerous.*

- a. When "ON" of push button switch [113] is pushed, spindle [94] rotation starts.
- b. Handle [37] turns and drill touches to workpiece, and spindle rotates, then drilling is possible. When the handle [37] turns until scale of sleeve [41] moves to "0" of name plate [84], drilling completes. If you release handle, spindle [94] returns automatically by power of spiral spring [90].
- c. When operation finishes, please push "OFF" of push button switch [113] and stop spindle rotation.

## 7 . MAINTENANCE AND CHECK

 CAUTION

- ◆ *When you finish work or check machine, please push "OFF" of push button switch and stop motor.  
And please turn off power supply breaker.*

- (1) Please clean chips etc. finely after finish working.
- (2) Please refuel lubricating oil according to 4-(4) before operation start.
- (3) Check of each part  
Please check condition of V belt, spindle up-down movement and abnormal noise of rotation part sometimes before start working.  
If you find any abnormal portion, please stop working and repair it.



### 8-1. DIMENSION (Round table)

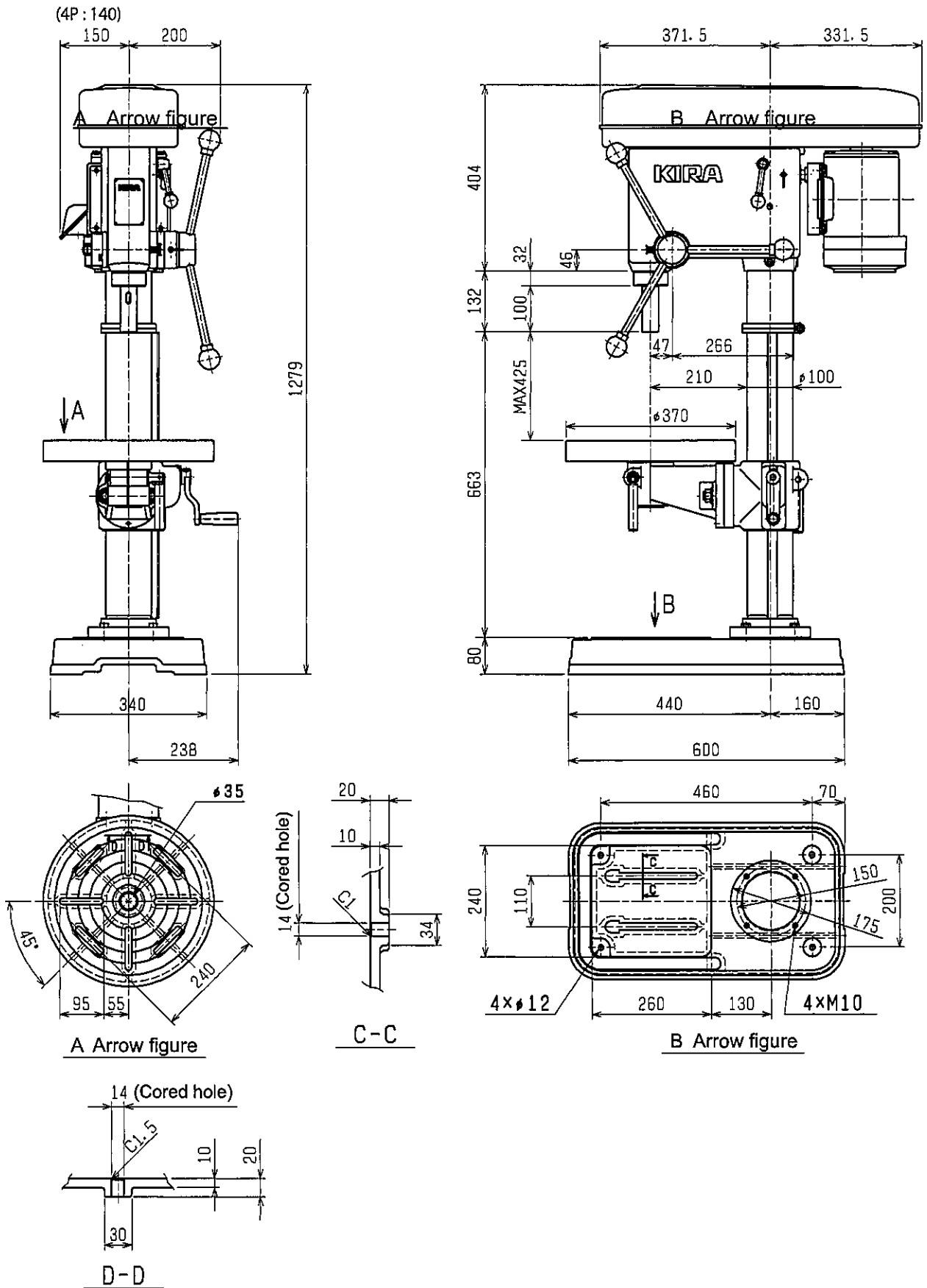

## 8-2. DIMENSION (Square table)

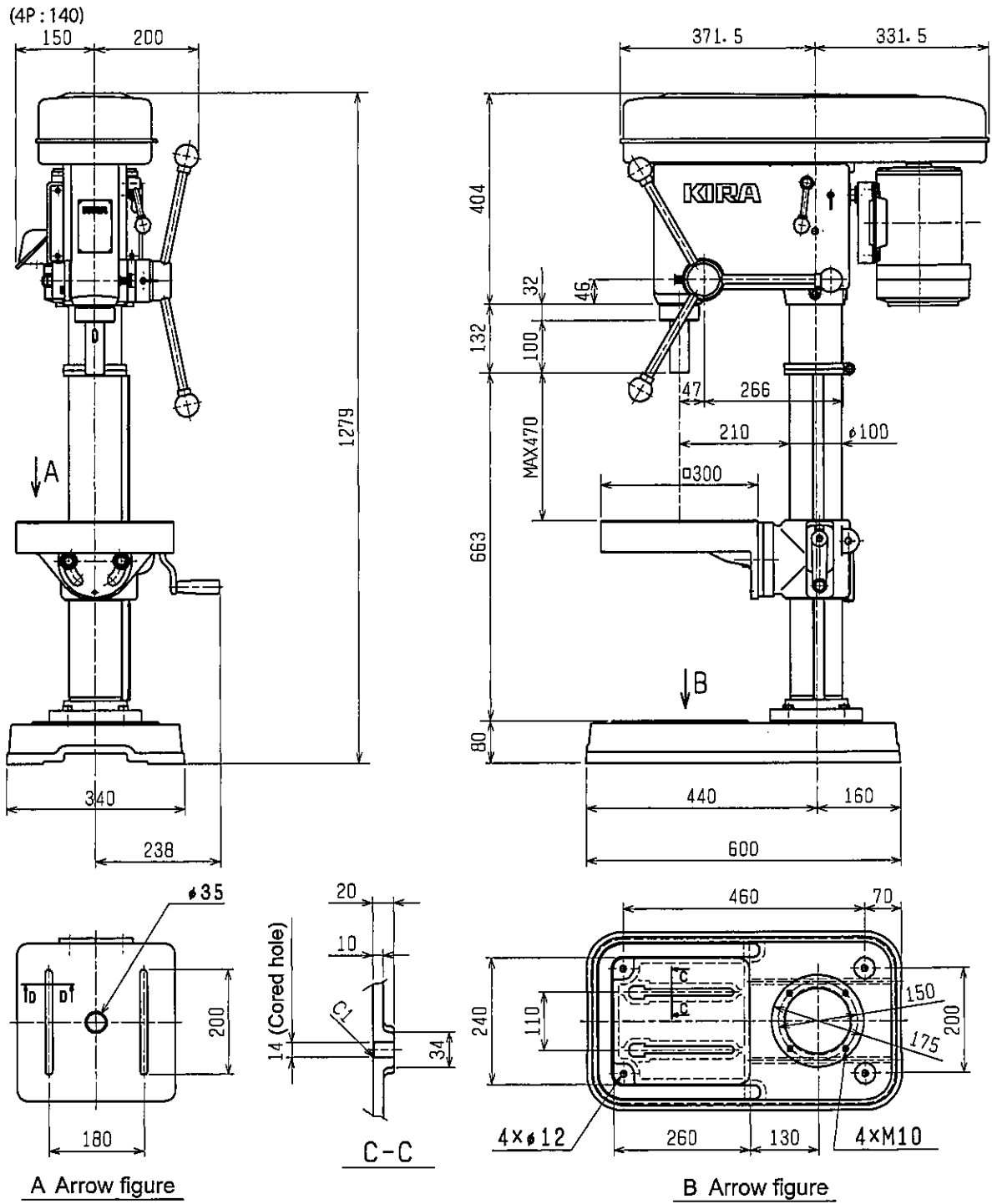

A Arrow figure

B Arrow figure

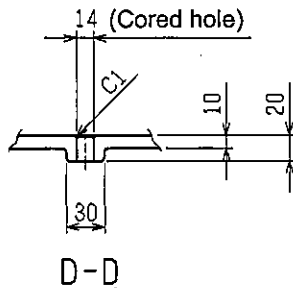

D-D

### 8-3. DIMENSION (Round table MT3 (Option))

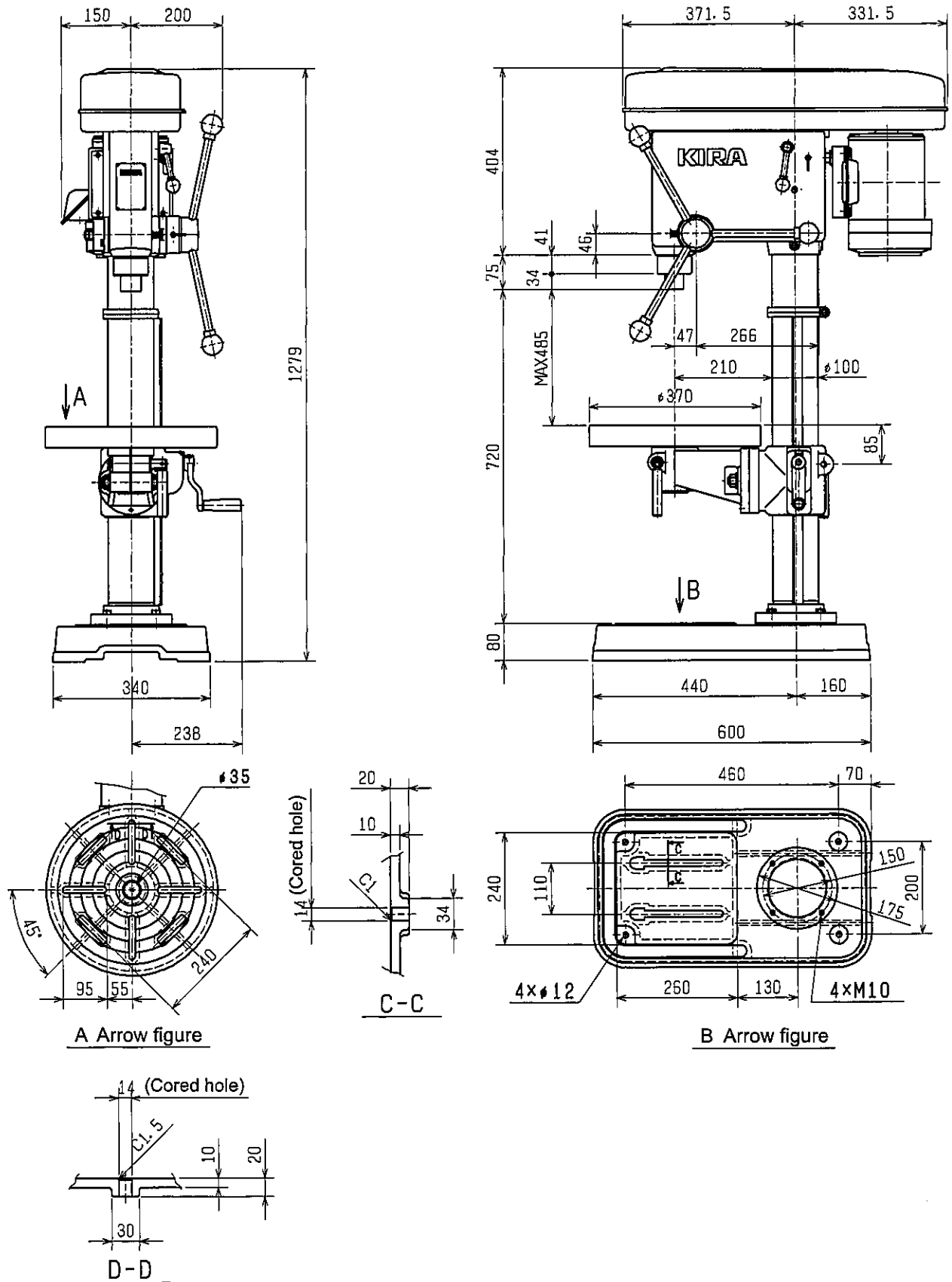



# 9. PARTS LIST

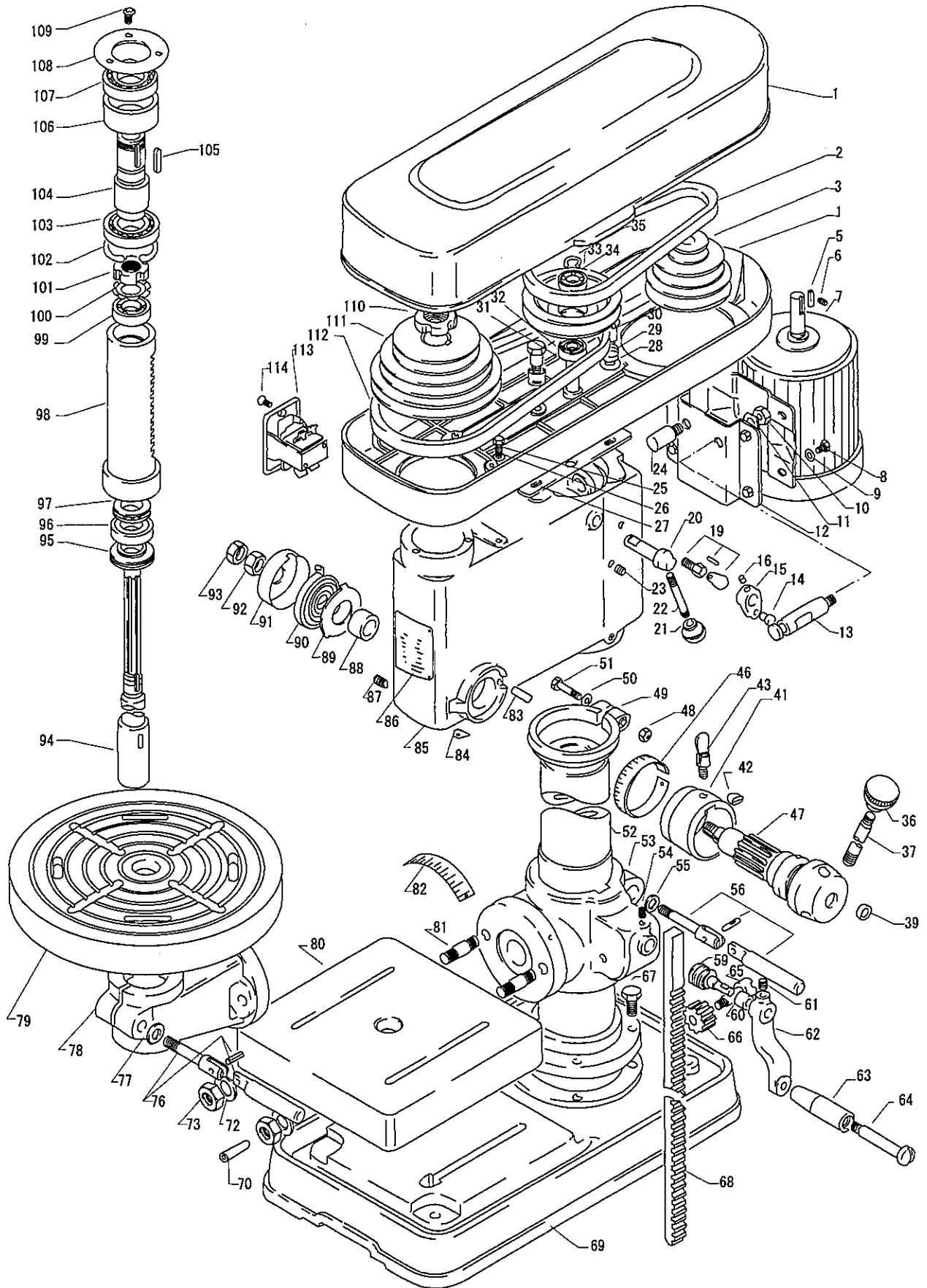

9. PARTS LIST

NO	Spec	Parts No.	Parts Name	Remarks	Q'ty
1		2C-2601-A	Cover Ass'y		1
2	74	BL1-A-26-R	V Belt	A-26	1
2	76	BL1-A-27-R	V Belt	A-27	1
3	74	KI-2360-1B	Pulley (Motor)	4B-2360(material)	1
3	76	16B-2360-1A	Pulley (Motor)	4B-2360(material)	1
5	74	OTZ-06*06*025HH	Parallel Key	Attached motor	1
5	76	OTZ-08*07*035HH	Parallel Key	Attached motor	1
6		BTA-M06*012-K	Hex. socket head stop screw	M6*12(Cup point)	1
7	74	MO1-0.75KW*4*200A	Motor	FEQ-80LHTS(18)	1
7	76	MO1-0.75KW*6*200B	Motor	MLH6097F	1
8		BT1-M08*020	Hex. bolt	M8*20	4
9		ZG1-M08-U	Plain washer	M8	4
10		NT1-M12	Hex. nut	M12	2
11		ZG2-M12	Spring washer	M12	2
12	74	KI-2364-4C	Base(Motor)		1
12	76	4C-2364-2B	Base(Motor)		1
13		4B-2365-3B	Guide		1
14		3B-2376-A	Pin		1
15		3B-2374-A	Shifter		1
16		BTA-M10*012-K	Hex. socket head stop screw	M10*12(Cup point)	1
19		BT1-M10*030	Hex. bolt	M10*30	1
20		4B-2368-2C	Shaft		1
21		KN-41-A	Knob		1
22		2C-2341-A	Handle		1
23		BTA-M12*015-K	Hex. socket head stop screw	M12*15(Cup point)	4
24		4B-2366-2B	Guide		1
25		BT1-M08*015	Hex. bolt	M8*15	4
26		ZG1-M08-U	Plain washer	M8	4
27		3C-2321-A	Holder		1
28		OTZ-M14-t3.2	Plain washer	M14(t=3.2)	2
29		3C-2330-B	Coil spring		2
30		3C-2323-A	Pin		2
31		KI-2324-B	Shaft		1
32		BE1-6203ZZ	Ball bearing	6203ZZ	1
33		4B-2325-A	Pulley		1
34		BE1-6203ZZ	Ball bearing	6203ZZ	1
35		RG1-S017	Stop ring	S17	1
36		KI-52-A	Knob		3
37		KI-51-A	Handle		3
39		R-42-C-A	Name plate		1
41		KI-49-2A	sleeve		1
42		KI-53-1A	Clamp piece		1
43		AS1-NR54-1	Clamp bolt with handle		1
46		KI-50-B	Name plate		1
46		BTD-#2*5	Tack	#2*4.8	2
47		AS0-KI46-2	Pinion shaft (Ass'y)		1
48		NT1-M08	Hex. nut	M8	1
49		KI-89-B	Stop ring		1
50		ZG1-M08-U	Plain washer	M8	1
51		BT1-M08*055	Hex. bolt	M8*55	1

NO	Spec	Parts No.	Parts Name	Remarks	Q'ty
52	C	KI-2-F	Column		1
52	200L	KI-2-4D	Column	200 mm (Long)	1
53		KI-4-G	Bracket		1
54		BTA-M06*015-K	Hex. socket head stop screw	M6*15(Cup point)	1
55		ZG1-M12	Plain washer	M12	1
56		AS1-KI-5-1B	Clamp bolt with handle		1
59		KI-78-1	Shaft (Worm)		1
60		KI-79-A	Bush		1
61		BTA-M08*012-K	Hex. socket head stop screw	M8*12(Cup point)	1
62		KI-81-D	Handle		1
63		KI-1060-D	Knob		1
64		KI-1059-C	Pin		1
65		KI-77-B	Shaft		1
66		KI-76-A	Gear(16T)		1
67		BT1-M10*035	Hex. bolt	M10*35	4
68		KI-85-D	Rack	16*20*620	1
69		KI-1-C	Bed		1
70		PN2-06*030	Taper pin	6*30	1
72		ZG1-5/8-A	Plain washer	5/8	2
73		NT1-M16	Hex. nut	M16	2
76	R4	AS1-KI-5-1A	Clamp bolt with handle		1
77	R4	ZG1-M12	Plain washer	M12	1
78	R4	KI-4R-D	Holder		1
79	R4	KI-7R-D	Table		1
80	S4	KI-7-D	Table		1
81		KI-8-A	Bolt		2
82	S4	KI-4-2B	Name plate		1
82	S4	BTD-#2*5	Tack	#2*4.8	2
83		PN2-06*030-N	Taper pin	6*30	1
84		NR-52-A	Name plate		1
84		BTD-#2*5	Tack	#2*4.8	1
85		KI-2001-I	Head		1
86		KI-2801-8A	Name plate		1
86		BTD-#2*5	Tack	#2*4.8	4
87		2C-2115-A	Key	BTG-M10*020	1
88		KI-2240-A	Bush		1
89		KI-2242-A	Holder (Spring)		1
90		KI-56-B	Spiral spring		1
91		KI-2244-A	Spring case		1
91		AS1-KI-2244-A	Spring case set		1
92		3B-2219-A	Nut		1
93		3B-2245-A	Nut		1
94		KI-20-5J	Spindle	( $\phi$ 38*523)	1
95		KI-21-5B	Collar		1
96		BE1-6006ZZ	Ball bearing	6006ZZ	1
97		BE6-51106	Thrust ball bearing	51106	1
98		KI-15-5H	Rack sleeve		1
99		BE1-6005ZZ	Ball bearing	6005ZZ	1
100		ZG5-AW05	Bearing washer	AW05	1
101		NT3-AN05	Bearing Nut	AN05	1
102		RG1-R072	Stop ring	R72	1

9. PARTS LIST

NO	Spec	Parts No.	Parts Name	Remarks	Q'ty
103		BE1-6207ZZ	Ball bearing	6207ZZ	1
104		KI-27-5D	Shaft		1
105		KY1-05*05*028RR	Parallel Key	5*5*28RR	1
106		COL1-062070035B	Collar(1)	KI-29(Previous)	1
107		BE1-6207ZZ	Ball bearing	6207ZZ	1
108		KI-30-A	Cover		1
109		BT6-M06*010	Cross recessed head machine screw	M6*10	3
110		NT3-AN07	Bearing Nut	AN07	1
111		4B-2309-B	Pulley		1
112		BL1-A-34-R	V Belt	A-34	1
113		KI-2702-2	Push button switch	BSP215NB3KRC	1
114		BT7-M04*008	Countersunk head screw	M4*8	2
115		KI-86-A	Bush	Rubber bush	2
116		2C-2114-A	Packing		1
117	76	KI-2801-6	RPM Name plate		1
118	76	COL1-024033011B	Collar	KI-2361-2(Previous)	1



## 10. DISPOSAL AND RESELLING

### 10.1 Disposal

Please handle the following items industrial wastes in accordance with regulation of your country.

- (1) Cutting oil and lubrication oil
- (2) Chip
- (3) Tools
- (4) Main unit

For disposing of them, contact us.

### 10.2 Reselling

#### CAUTION

- ◆ *To resell the KID-420 to any other party, strictly observe the following instructions:  
Be sure to hand the Instruction Manual to that new user.  
See the chapter indicating the locations of signal-word labels and make sure that all the labels are in place.  
If the Instruction Manual or any of the signal-word labels is missing, be sure to contact us to obtain it.  
Before reselling the KID-420, contact us without fail.*
- ◆ *You, as purchaser of this machine, agree to follow the procedures for the export or transfer of the machine, under the Foreign Exchange and Foreign Trade Law, when you export or transfer the machine abroad.  
This machine was produced to meet the law and specifications in your country (or area).  
You, as purchaser of the machine, are not allowed to re-sell, re-export, or re-transfer the machine to any party in the country (or area) which has different law and specifications from those in your country.*

## 11. WARRANTY

### 11.1 Free Repairs

- 1) If a malfunction or a failure occurs during the normal use strictly based on the operation guidelines (given in the Instruction Manual), the Instruction Manual, the signal-word labels, and other instructions, then it is repaired free of charge within the warranty period.
- 2) Our warranty only covers the delivered main unit and does not apply to any loss and/or damage, direct or indirect, resulting from such malfunction or failure.
- 3) The warranty remains valid for one year after the delivery with your acceptance.

### 11.2 Charged repairs

The repairs after the warranty period and those in the following cases within the warranty period are charged to you:

- 1) A malfunction, failure, or damage has resulted from the misuse of the KID-420; or from the modification or repair made without obtaining our consent.
- 2) A malfunction, failure, or damage has resulted from fire, acts of God, lightning, abnormal voltage, or any other unpredictable situation.
- 3) A malfunction, failure, or damage has resulted from your improper handling such as falling during the transportation or transfer by you.
- 4) A malfunction, failure, or damage has occurred because you have failed to follow the operation guidelines.
- 5) Consumable items have been used up, worn out, or otherwise have deteriorated after the normal use.

### 11.3 Locations for contact

Sales Department of Main Office :

TOMIYOSHI SHINDEN, KIRA-CHO NISHIO-CITY, AICHI PREF.,  
444-0592, JAPAN

TEL 81-563-32-0100

FAX 81-563-32-3241

E-Mail :<info@kiracorp.co.jp>

# KIRA CORPORATION

---

Revision history

1st edition : September 19, 2016

**KIRA**